



HYDRAULIC / ELECTRIC / MULTIZONE

# ECOFRIDGE SLIMLINE 215MTL

MULI TEMP IN 2 LANES



**Slimline 215MTL is a special hydraulic and electric powered unit** for two separate longitudinal temperature zones. Both temperature zones are controlled and monitored from the cab from a single control panel.

The unit has type designation Slimline MTL is equipped with our HUA control system. The unit is mounted externally on the front wall.

ECOFRIDGE

# Slimline 215MTL

- ▶ Hydraulic constant flow pump delivers full power regardless of speed
- ▶ Fuel savings of up to 60%
- ▶ Reduced CO<sub>2</sub>, NO<sub>x</sub> & PM emissions
- ▶ Lower service costs
- ▶ Mounts between the box and cab
- ▶ Mains connection 400 V
- ▶ HUA control system

## FUNCTION

The unit is powered by a hydraulic constant flow pump which is mounted directly on the truck's PTO and provides constant power whatever the engine speed. A 4-cylinder 560 cm<sup>3</sup> compressor manufactured by Bock ensures a high and reliable refrigeration capacity.

The multi-evaporator system in the EcoFridge Slimline MTL can be supplied in two different versions: with a defined freezer or refrigerator space, or with a fridge-freezer and heating in both spaces. The unit can also be connected to the mains. Heat is provided by electric and water heaters.

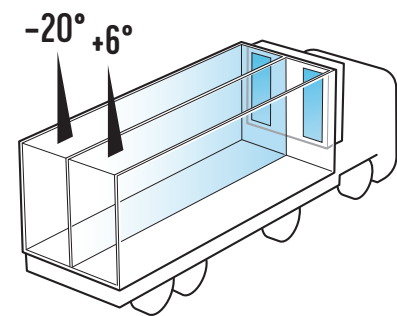

Special flexible unit with two different temperature zones.

## TECHNICAL SPECIFICATIONS

Model	Refrigeration capacity*			Electric power*			Standard heat	Extra heat Water	Multizone	Weight
	Box temp 0°C	Box temp -10°C	Box temp -20°C	Box temp 0°C	Box temp -10°C	Box temp -20°C				
Slimline 215MTL	9 200 W	7 000 W	5 000 W	6 300 W	6 000 W	4 700 W	Yes	Option	Yes	500 kg

\*Refrigeration capacity specified at +30°C ambient temperature.

## DIMENSIONS

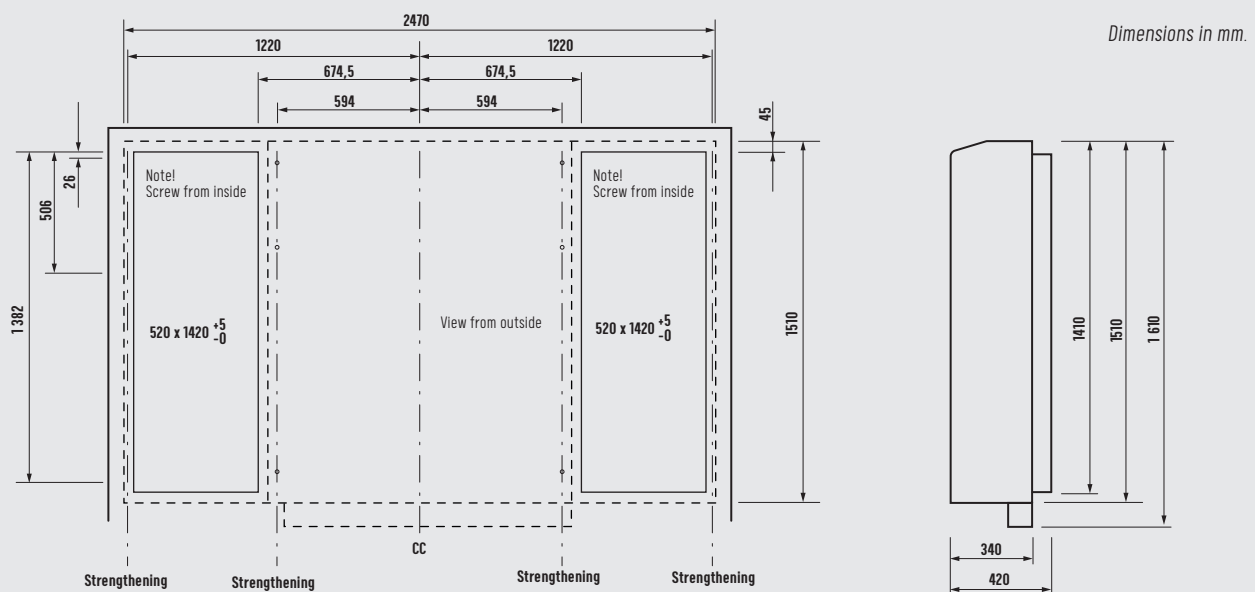

# HULTSTEINS