



EXTERNAL EVAPORATOR
MULTILINE 7MTL/8MT



HULTSTEINS EXTERNAL EVAPORATORS MULTILINE are available in two sizes, 7 and 8, and can be combined with several of our larger units. The evaporator is controlled from the cab using the same control panel as the main unit.

EXTERNAL EVAPORATOR

MULTILINE

- ▶ Hydraulic constant flow pump delivers full power regardless of speed
- ▶ Fuel savings of up to 60 %
- ▶ Reduced CO₂ emissions
- ▶ Lower service costs
- ▶ Mounted in box roof
- ▶ 400 V mains connection
- ▶ HUA control system

FUNCTION

THE UNIT IS POWERED VIA THE MAIN UNIT and is available in two sizes, 7 and 8, with its own additional heating, and is operated from the cab using the same control panel as the main unit.

The result is a number of refrigeration zones in the box of the truck and the ability to transport both chilled and frozen goods in the same transport. It is also possible to mount an evaporator at the rear of the box to achieve the same temperature throughout the entire cargo space and then to divide the box crosswise with a movable wall.

The evaporators can only be ordered together with main units:
Slimline 15, Topline 13/16 and Lowline 13.

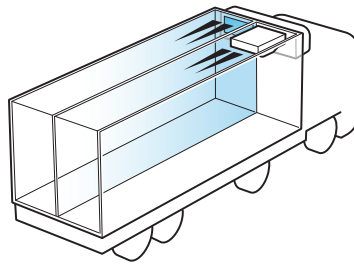

Multiline 7MTL is a slim unit - only 800 mm wide (one pallet width). It can be fitted in a refrigeration corridor both at the front and the rear.

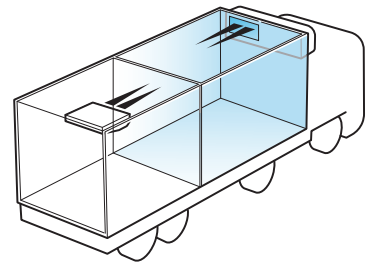

Multiline 8MT is 1100 mm wide and can be mounted in several places. A suitable solution for a movable partition that divides the box crosswise.

TECHNICAL SPECIFICATIONS

Model	Electric heating	Additional heating Water	Weight
Multiline 7MTL	1800 W	Optional	22 kg
Multiline 8MT	1800 W	Optional	30 kg

DIMENSIONS

Multiline 7MTL

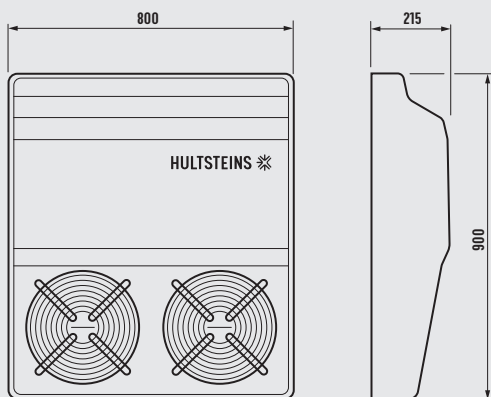

Multiline 8MT

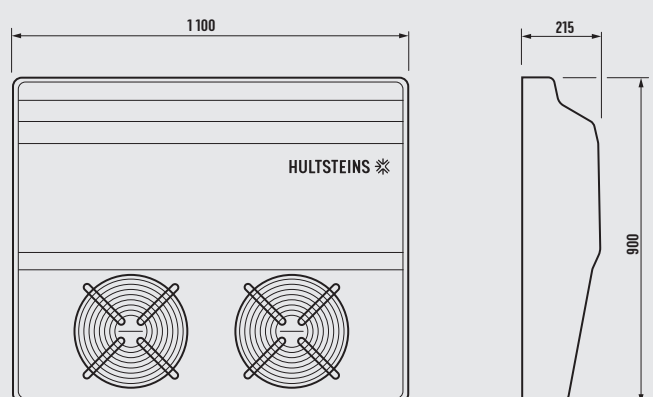

Dimensions in mm

HULTSTEINS 